

# Development of a Small Portable Device for Measuring Respiratory System Resistance Based on Forced Oscillation Technique

Wei Chang<sup>1,2</sup>, Kuibi Shi<sup>1,2</sup>, Zhiguo Zhang<sup>1</sup>, Changchun Yang<sup>2</sup> and Linhong Deng<sup>1,2,\*</sup>

<sup>1</sup>Changzhou Key Laboratory of Respiratory Medical Engineering, Institute of Biomedical Engineering and Health Sciences, Changzhou University, Changzhou, 213164, China

<sup>2</sup>School of Mathematics and Physics-Information Science and Engineering, Changzhou University, Changzhou, 213164, China

**Abstract:** Spirometry and forced oscillation technique (FOT) are two different methods that are currently used for lung function test. However, the former requires patient's effort to cooperate, thus is often unreliable for certain patients such as the young children and the latter is always related to bulky and expensive machines. In order to overcome the limitations of current device, we developed a portable prototype of FOT device for measuring respiratory resistance. The device consisted of a small advanced voice coil actuator to generate sinusoidal oscillatory airflow with amplitude of 2.5 cmH<sub>2</sub>O and frequency of 5 Hz, which was then superimposed onto the normal breathing airflow of the patient via a mouth piece. The pressure and flow signals of the respiratory airflow after absorption and refraction by the airways and the lung tissues were detected and acquired using NI USB-6211 data acquisition card and synchronous sampling pressure and flow sensors. After the upper computer received the digital signals that the capture card converted, the signals were processed and analyzed in real-time by the proprietary LabVIEW-based software. The analysis included digital signal filtering and impedance calculation in frequency domain, resulting in respiratory system resistance ( $R_{rs}$ ) and reactance ( $X_{rs}$ ). The results of present experiments on healthy volunteers demonstrated that the device could measure the respiratory system resistance with good reliability and accuracy. Importantly, due to both the hardware and software design the weight and volume of this device was reduced down to 3.5kg and 2500 cm<sup>3</sup>, respectively, proving the prototype to be worth of further developing into an inexpensive and portable tool for testing or monitoring lung function at rural community clinics or homes.

**Keywords:** Forced oscillation technique (FOT), Respiratory system resistance, Signal processing, Filter, Spirometry.

## 1. INTRODUCTION

With the deterioration of air pollution, chronic respiratory diseases have become major risks to public health. Among them, chronic obstructive pulmonary disease (COPD) and asthma are the most prevalent. A national survey in China ranked COPD as the 4<sup>th</sup> leading cause of death in the urban population, and the 1<sup>st</sup> in the rural population [1]. The total number of asthma patients in China has reached more than 30 million and is still rising, while the mortality of asthma in China remains one of the highest in the world [2].

These diseases share one common feature of pathology, *i.e.* respiratory airflow limitation due to airway obstruction. Therefore, measurement of respiratory airflow resistance has become the most important and widely used tool in clinical practice for diagnosing chronic respiratory disease. Currently, the gold-standard method for measurement of respiratory resistance is the so-called spirometry that mainly measures the amount (volume) and/or speed (flow) of

air that can be inhaled and exhaled through the airways [3]. This method is the most reliable for determination of reversible airway obstruction, but it requires a high degree of cooperation by the test subject. This makes it hard to be properly operated on a variety of subgroups of people such as infants, young children, old age/disabled/paralyzed people, and thus often leads to unreliable measurement and un/misdiagnosed cases [4].

To overcome this problem, Dubois and his colleagues in 1956 first introduced the forced oscillation technique (FOT) as an alternative method for measuring respiratory resistance, which does not require active cooperation of the test subject [5]. FOT is to impose a sine pressure wave oscillating at specific frequency and amplitude on the test subject through a mouth piece. This pressure wave is then superimposed onto the breathing airflow of the test subject without effort of the subject. The signals of the pressure and flow rate of this mixed airflow are detected by pressure/flow sensor detection system and processed by signal processing system that fully optimizes the quantification of the respiratory system's impedance to the flow of the imposed pressure wave [6].

\*Address correspondence to this author at the Institute of Biomedical Engineering and Health Sciences, Changzhou University, Changzhou, Jiangsu, 213164, China; Tel: +86 0519-86330988; Fax: +86 0519-86330988; Email: dlh@cczu.edu.cn

As a complex number, the impedance consists of a real component named the resistance, and an imaginary component named the reactance of the respiratory system. The resistance measures the viscous resistance of the lung, which reflects the extent of limitation to airflow in the airways due to airway obstruction. The reactance measures the elastic resistance of the lung, which reflects the compliance of the respiratory system including airway wall and lung parenchyma. In recent years, FOT has become increasingly popular as lung function test for diagnosis of asthma, COPD and other obstructive airway diseases. It has also been used for real-time monitoring of respiratory impedance during the course of treatment of sleep-disordered disease using positive pressure ventilation [7].

However, the currently available FOT systems are all in bulky size because they use large size acoustic speakers (10 Kg and 0.5 m<sup>3</sup>) as the source of oscillatory pressure waves, and they are usually designed with complex hardware circuits for signal processing. This largely limits its use in fair-sized hospitals, even though there is a much wider demand for access to such device at small community healthcare clinics or even at home. Therefore, we developed a small portable and inexpensive FOT device that may have great potential to be substitute of its bulky counterpart for use in small community clinics or even at homes.

In our design we used an advanced small voice coil actuator as oscillation source to produce a sinusoidal pressure oscillation wave at 5Hz frequency and 2.5 cm H<sub>2</sub>O amplitude. The signal processing system was based on the software of LabVIEW virtual instrument platform together with NI USB-6211 data acquisition card, which can be easily reconfigured to achieve powerful digital signal processing, ensuring efficient and accurate measurement [8]. This device facilitated synchronous sampling data of pressure and flow

sensors, real-time analysis of pressure and flow signals and corresponding respiratory impedance in a highly compact physical form with small footprint. Experimental test results on healthy volunteer showed that this FOT device was able to satisfactorily detect and quantify respiratory system impedance, while its weight and volume was reduced to 3.5 kg and 0.0025 m<sup>3</sup>. Thus it provided a promising prototype to be further improved and validated.

## 2. HARDWARE DESIGN AND DEVELOPMENT

### 2.1. Structure of the FOT Device Hardware System

Figure 1 (A) showed the FOT device hardware structure, including an oscillation source, a pressure sensor, a flow sensor, a data acquisition card and a computer. The oscillation source produced a sinusoidal pressure wave at 5Hz and 2.5 cmH<sub>2</sub>O amplitude, generating an oscillatory airflow through a low resistance, high-inertance draft tube (25 mm in internal diameter and 50 cm in length). The oscillatory airflow was then superimposed onto the respiratory airflow of the test subject via a mouth piece when the subject was breathing at rest. The draft tube was designed so that the airflow in the tube was smooth. The pressure and flow signals were collected by the data acquisition card simultaneously, and then were transferred to the computer. At last, the computer will process the signals and calculate the impedance of the respiratory system. Figure 1 (B) showed the real prototype of the FOT system.

### 2.2. Voice Coil Actuator

The most advantage in the design of this FOT device was the usage of an advanced small size voice coil actuator as the source of oscillation as shown in Figure 2. The voice coil actuator is a commercial product of Kunshan Tongmao Electronics CO.

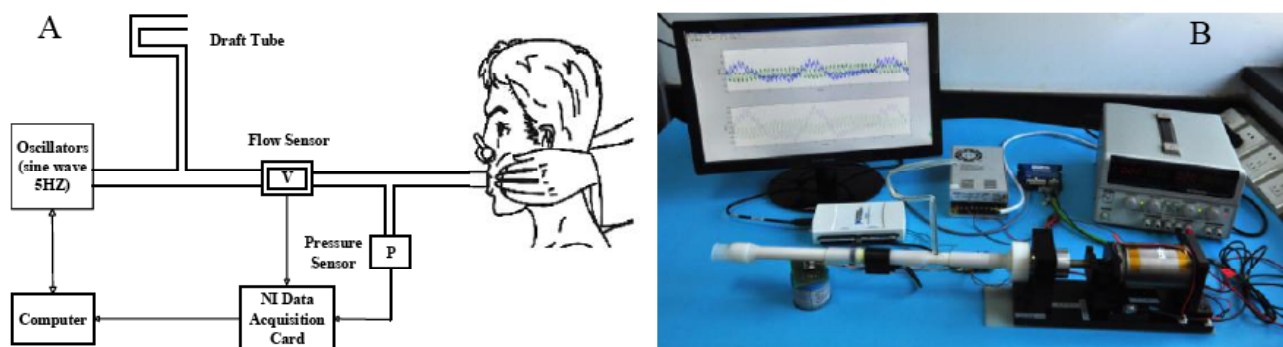

**Figure 1:** Scheme of the FOT device hardware structure (A) and the real prototype of the FOT device (B).

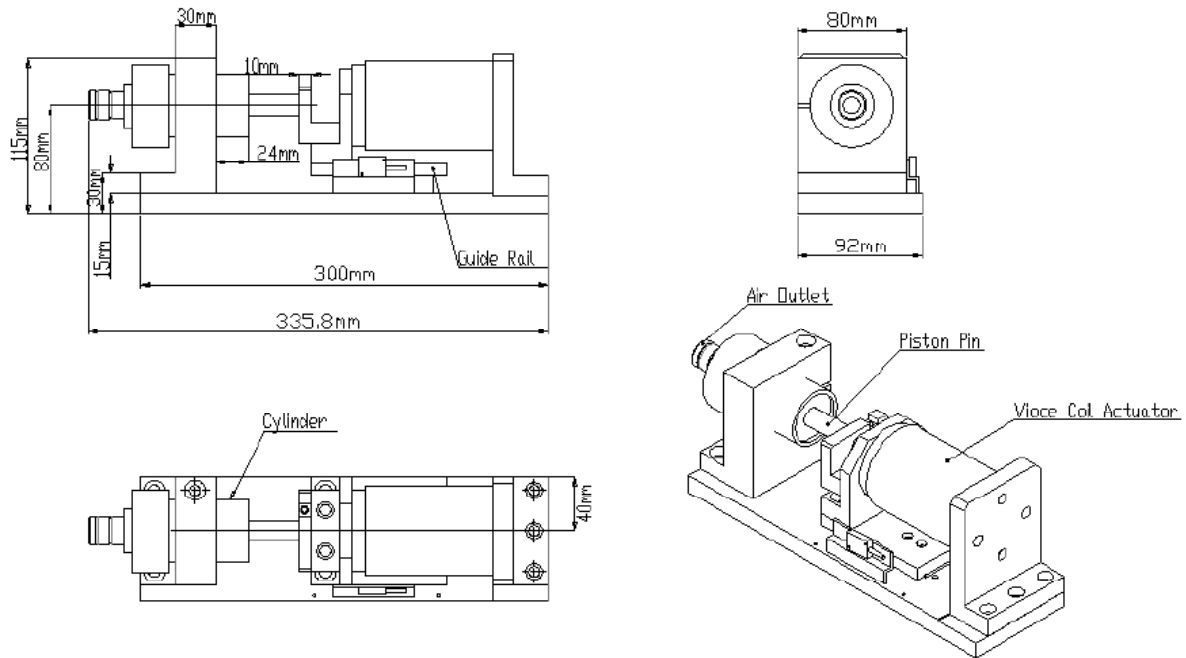

**Figure 2:** Diagram of the voice coil actuator.

Ltd(Kunshan, Jiangsu, China). The electric motor in the voice coil actuator drove the piston pin in a reciprocating motion back and forth to generate a 5Hz sine wave pressure in the draft tube connected to the air outlet of the mechanism. In order to achieve the accurate amplitude of 2.5 cmH<sub>2</sub>O for the pressure wave in the draft tube, we first made coarse calibration of the pressure value in the draft tube versus different diameter sized draft tubes, using pressure sensor to read the pressure value. After the diameter of the draft tube was determined (in this case, 25 mm), we made fine calibration of the pressure value by adjusting the stroke of the voice coil actuator at 1 $\mu$ m resolution.

### 2.3. LabVIEW-Based Software Design and Development of the FOT Device

The other advantage of this FOT device was the development of LabVIEW-based software of signal processing and analysis. LabVIEW is a virtual instrument platform developed by National Instruments (NI, Texas, USA), similar to C and Basic development environment. Unlike other computer languages that use text codes, LabVIEW uses graphical editing language G to write program in block diagram form that is ideal for developing measurement and control instrument systems. For acquisition of synchronous sampling data of pressure and flow sensors, we used NI USB-6211 data acquisition card. NI USB-6211 is a bus-powered USB M series multifunction DAQ module that can

maintain a 3.512mV high precision at high sampling rate. This module provides 16 analog input, single-channel sampling rate at 250 kS/s, 2-channel analog output, 4-channel digital input lines, 4-channel digital output lines, meeting the design requirements of the FOT device. The LabVIEW-based software was designed to complete all the functions of measurement and control of the FOT device including real-time reading flow and pressure data, digital signal filtering, and data analysis for impedance calculation. LabVIEW data acquisition program as shown in Figure 3.

### 2.4. Digital Filter Design

By using digital filter design with the LabVIEW-based software to replace the traditional hardware filter circuit, The FOT device was further reduced in volume size. The digital filter as designed with the LabVIEW-based software could remove the signal measurement noise just as well. Figure 4 shows the spectrum waveform of flow and pressure signals before digital filtering, at the frequency range of 0-100 Hz (the upper panel), and the more detailed waveform in the range between 0~10Hz (the lower panel).

From the spectrum it can be seen that during acquisition the signal mainly included the spontaneous respiration (signal components below 1Hz, esp. at about 0.3Hz), the 5Hz forced oscillation wave signal energy and the 50Hz mains interference from the

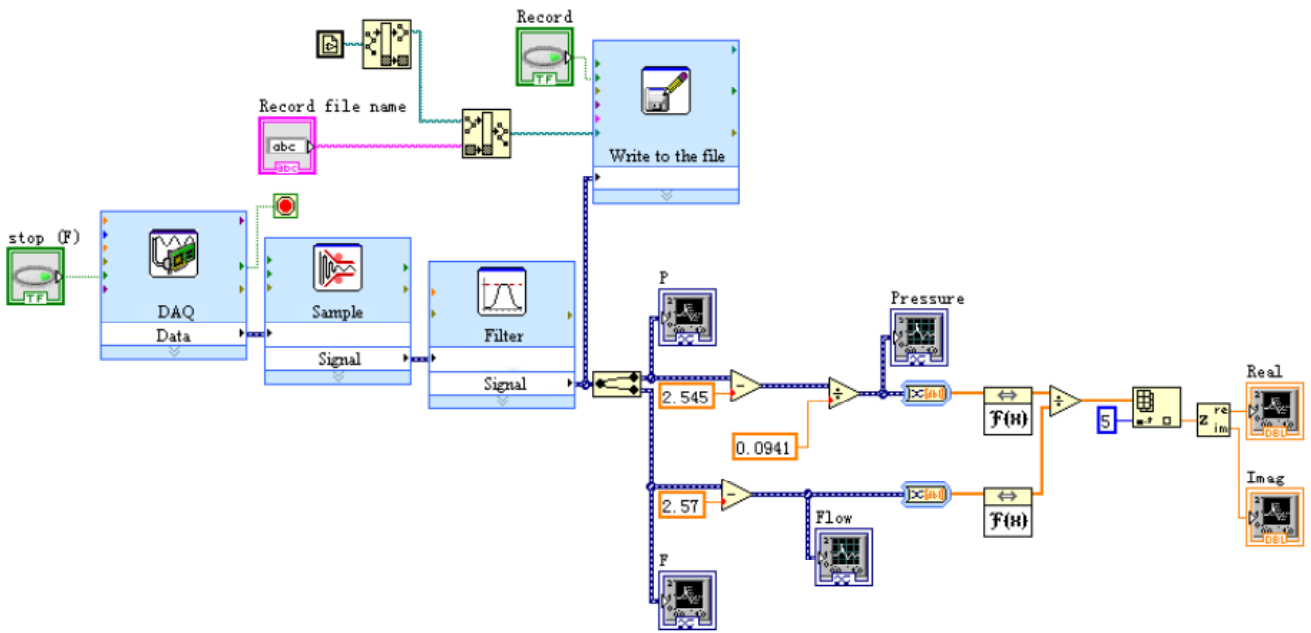

Figure 3: LabVIEW data acquisition program.

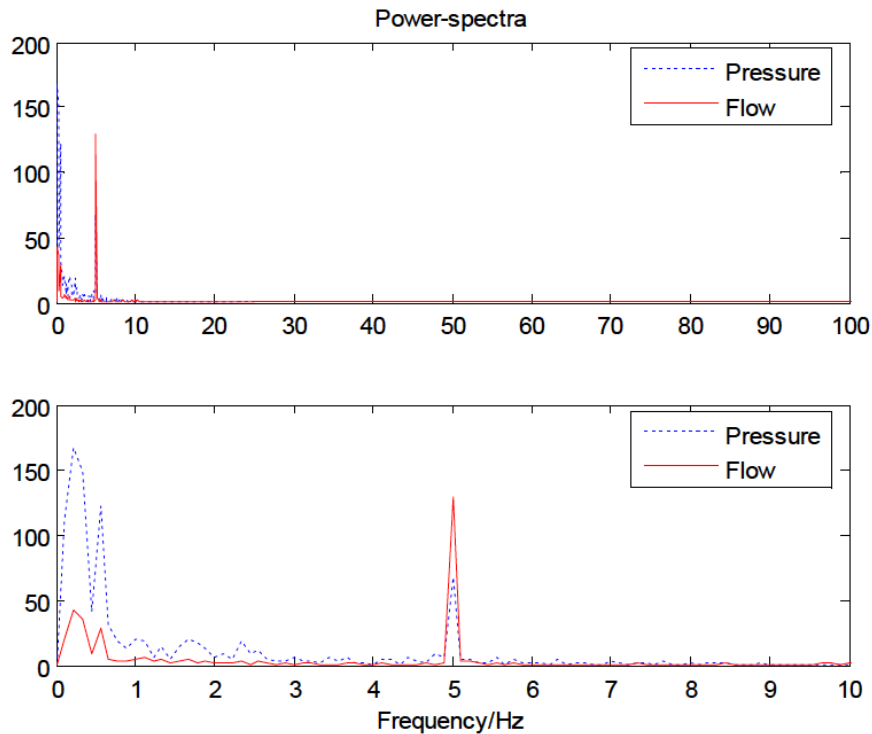

Figure 4: Pressure and flow spectrum waveform.

power-line. Considering that in the signals, all the effective components relevant to respiratory system impedance estimation are below 20Hz, we designed a finite impulse response (FIR) low-pass digital filter to filter out high-frequency and power-line noise interference.

### 3. CALCULATION OF RESPIRATORY SYSTEM RESISTANCE

For calculation of respiratory system resistance, we used a frequency domain analysis method adopted from that as reported by Horowitz *et al.* [9]. For a given

oscillating pressure  $P(t)$  and corresponding flow  $V(t)$  measured from the respiratory system, the total respiratory system impedance ( $Z_{rs}$ ) is

$$Z_{rs} = P(t) / V(t) \quad (1)$$

$Z_{rs}$  is a complex quantity that contained a real, and an imaginary part, which could be expressed as:

$$Z_{rs} = R_{rs} + jX_{rs} \quad (2)$$

$R_{rs}$  is the component in the same phase of the pressure and flow signals that reflected the viscous resistance of the airways and the lung tissues.  $R_{rs}$  is mainly due to the large to small airways, therefore is termed respiratory system resistance or airway resistance.  $X_{rs}$  is the component out of the phase of the pressure and flow signals that reflected the elastic and inertial resistance of the airways and the lung tissues.  $X_{rs}$  is mainly due to the small bronchi and the lung tissues (elastic resistance) and the airways and the chest (inertial resistance).

$P(t)$  and  $V(t)$  are both time varying functions. By using triangular form of Fourier series, they could be transformed as the following:

$$P(t) = a_0 / 2 + \sum_{k=1}^{\infty} (a_k \cos 2 \Pi fkt + b_k \sin 2 \Pi fkt) \quad (3)$$

In the equation,  $t_1 - T / 2 \leq t \leq t_1 + T / 2$ ,  $t_1$  is any point in time and  $a_0/2$  is the DC component of the cycle function.  $a_k$  and  $b_k$  are real number that related to system response to external signals,  $k=1,2,3,\dots,\infty$ ,

$$a_k = \frac{2}{T} \int_{t_1-T/2}^{t_1+T/2} P(t) \cos 2 \Pi ftdt \quad (4)$$

$$b_k = \frac{2}{T} \int_{t_1-T/2}^{t_1+T/2} P(t) \sin 2 \Pi ftdt \quad (5)$$

Thus, the amplitude of the oscillating pressure at  $t_1$  is:

$$|P|_{t_1} = \sqrt{a_k^2 + b_k^2} \quad (6)$$

and the corresponding phase is:

$$\theta(P_{t_1}) = \arctan(-b_k / a_k) \quad (7)$$

Similarly, the amplitude of the oscillating flow is  $|V|_{t_1}$ , and the phase is  $\theta(V_{t_1})$ .

Accordingly, the amplitude and the phase of the impedance are:

$$|Z|_{t_1} = |P|_{t_1} / |V|_{t_1} \quad (8)$$

$$\varphi(t_1) = \theta(P_{t_1}) - \theta(V_{t_1}) \quad (9)$$

The amplitude and phase of the respiratory impedance at  $t_1$  are  $|Z|_{t_1}$  and  $\varphi(t_1)$ , respectively.

The respiratory system impedance is then expressed in the form of respiratory system resistance ( $R_{rs}$ ) and reactance ( $X_{rs}$ ) as :

$$|Z_{rs}| = \sqrt{R_{rs}^2 + X_{rs}^2} \quad (10)$$

$$\varphi_{rs} = \tan^{-1} \frac{X_{rs}}{R_{rs}} \quad (11)$$

Therefore,

$$R_{rs} = Z \cos \varphi \quad (12)$$

$$X_{rs} = Z \sin \varphi$$

Thus, the respiratory system resistance at each time point is calculated.

#### 4. THE EXPERIMENTAL TESTING OF THE FOT DEVICE

In order to validate the prototype FOT device, experimentally tested the device with 10 healthy adult volunteers, including 5 male and 5 female, respectively, with average height of 166 cm, average weight of 65kg and average age of 31.2y. The volunteer was tested at sit-up straight and resting state [10].

##### 4.1. The Measured Pressure and Flow Signals

Figure 5 shows the waveforms of pressure and flow signals as measured by the pressure and flow sensors. The upper panel shows the original waveforms before digital filtering, and the lower panel shows the waveforms after digital filtering by the FIR filter. It is clear that the digital filter was capable of effectively filtering out the measurement noise, thus ensuring the accuracy in the following calculation of the impedance.

Figure 6 shows waveforms of the calculated respiratory resistance,  $R_{rs}$  (upper curve), and reactance,  $X_{rs}$  (lower curve). It can be seen that  $R_{rs}$  and  $X_{rs}$  were in opposite phase so that  $R_{rs}$  approached its maximum value while  $X_{rs}$  approached its minimum value. The scope and time dependence of the variation

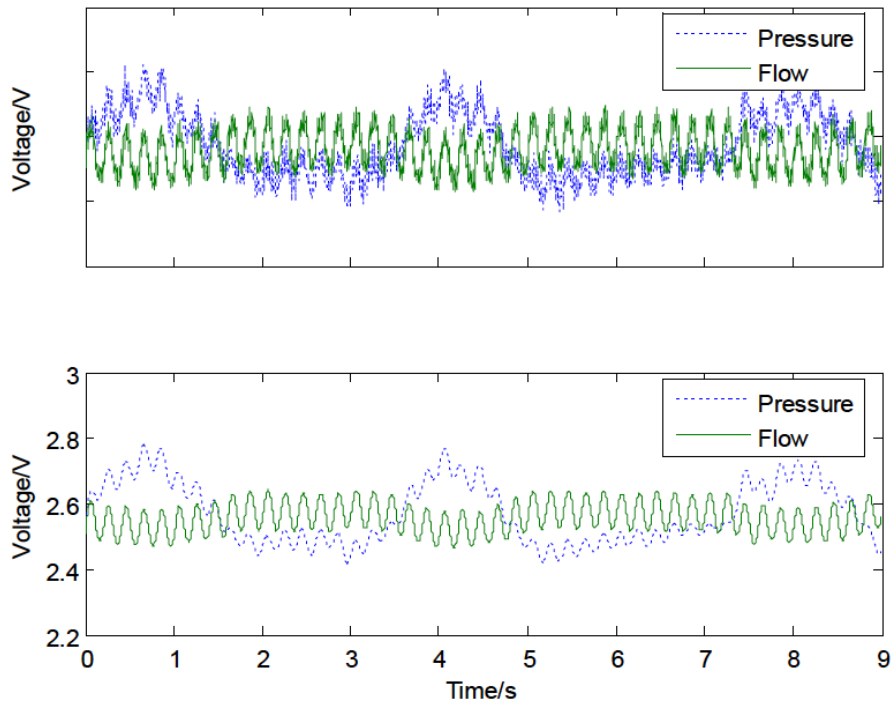

**Figure 5:** Waveforms of the pressure and flow signals before (the upper panel) and after (the lower panel) digital filtering by the FIR filter.

of  $R_{rs}$  and  $X_{rs}$  appeared to be reasonably consistent with the physiological values as predicted. Through the calculated, the average of the  $R_{rs}$  is  $4.61 \pm 1.33 \text{ cmH}_2\text{O} \cdot \text{s} \cdot \text{L}^{-1}$ ,  $X_{rs}$  is  $-4.12 \pm 1.79 \text{ cmH}_2\text{O} \cdot \text{s} \cdot \text{L}^{-1}$ , similar to the published artical results of  $R_{rs}$  is  $4.55 \pm 0.97 \text{ cmH}_2\text{O} \cdot \text{s} \cdot \text{L}^{-1}$  and  $X_{rs}$  is  $-3.16 \pm 1.36 \text{ cmH}_2\text{O} \cdot \text{s} \cdot \text{L}^{-1}$  [11].

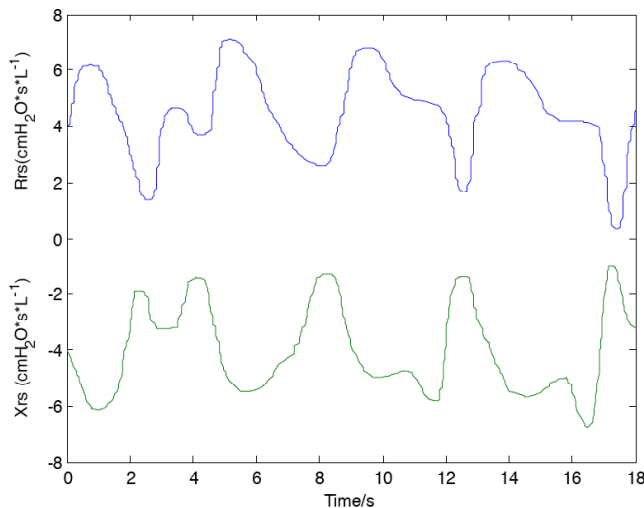

**Figure 6:** Impedance Map.

**DISCUSSION**

Forced oscillation technique is the only method that can be used with all types of patients and in any state of the patient, whether he/she is awake and breathing

autonomously or anesthetized. However, the currently available FOT devices use high power loudspeakers as the source of oscillating airflow, which makes them intrinsically bulky and difficult to operate, and thus are largely limited to be used in well-equipped hospitals. Here, we describe a novel small portable FOT device that is suitable to be used in small rural community clinics or even at homes. The design of the device with an advanced small voice coil actuator to replace the large loudspeaker and the digital filter to replace the hardware circuit filter reduced the weight and volume size of the device to  $3.5\text{kg}$  and  $0.0025\text{m}^3$ , respectively. The currently available FOT systems designed by large loudspeaker is approximate  $10\text{Kg}$  and  $0.5\text{m}^3$ . At the same time, the cost of the device was also reduced to approximately  $\$1,500$ , as compared to the price of about  $\$20,000$  for the commercially available FOT system.

The resulting respiratory system resistance,  $R_{rs}$  characterizes the viscous resistance of the airways and the lung tissues. Particularly, the high frequency component reflects the viscous resistance determined mainly by the size of the central airway, and the low frequency component reflects the viscous resistance determined by the size of all the airways. The respiratory system reactance,  $X_{rs}$  on the other hand characterizes the elastic resistance and inertial resistance of the airways and the lung tissues [4].

It should also be noted that the glottis movement during the measurement process can affect the measured signals. Therefore, to ensure the accuracy of the measurement, the software filter must be able to distinguish and remove the unusual signal fluctuations due to events not relevant to resting breath such cough or voice making during the test [12].

## CONCLUSION

In conclusion we introduced an FOT device that is small, portable, and convenient to operate. We use an advanced small size voice coil actuator as the source of oscillation to reduce the weight and volume of FOT device. The data acquisition and analysis was simplified by the proprietary LabVIEW-based software and NI-USB 6211 data acquisition card, which ensured the device to be accurate and efficient in synchronous data sampling and analysis as well as high in stability but low in power consumption and cost. We also verified that this device is capable of making reliable and credible measurement of respiratory resistance. Taken together this FOT device prototype had proved itself to be useful in assessment of airway obstruction, and, therefore, is probably worthy to be further improved and hopefully commercialized as a medical device for quick lung function test and monitoring at local community clinics or even at homes.

## ACKNOWLEDGMENTS

This study was sponsored by Changzhou Science and Technology Program for Changzhou Key Laboratory of Respiratory Medical Engineering (Grant no. CM 20133005).

## REFERENCE

[1] Liu D, Menjoge S. Statistical analysis of chronic obstructive pulmonary disease (COPD) exacerbations. *J European*

- Respiratory Journal*, 2008, 32(5): 1422-1423.  
<http://dx.doi.org/10.1183/09031936.00124108>
- [2] Sharpe HM, Sin DD, Andrews EM, *et al.* Alberta Strategy to Help Manage Asthma (ASTHMA): a provincial initiative to improve outcomes for individuals with asthma. *J Healthcare Quarterly*, 2004; 7(7): 55-60.  
<http://dx.doi.org/10.12927/hcq.16627>
- [3] Larsson M. Valuable methods for lung function measurements. Spirometry at ambulatory centers is excellent for early diagnosis. *J Lkartidningen* 1995; 92(47): 4435-7.
- [4] Oostveen E, Macleod D, Lorino H, *et al.* The forced oscillation technique in clinical practice: methodology, recommendations and future developments. [C]// *Computers in Cardiology* 2008; IEEE, 2008: 393-396.
- [5] Dubois AB, Brody AW, Lewis DH, *et al.* Oscillation mechanics of lungs and chest in man. *J Journal of Applied Physiology* 1956; 8(6): 587-94.
- [6] Scott B, Jonathan P, Burton L, *et al.* Impulse oscillometry: interpretation and practical applications. *J Chest* 2014; 146(3): 841-847.  
<http://dx.doi.org/10.1378/chest.13-1875>
- [7] Timmins SC, Diba C, Thamrin C, *et al.* The feasibility of home monitoring of impedance with the forced oscillation technique in chronic obstructive pulmonary disease subjects. *J Physiological Measurement* 2012; 34(1): 67-81.  
<http://dx.doi.org/10.1088/0967-3334/34/1/67>
- [8] Yan W, Yao W. Motor Measure and Control Software Design Based on LabVIEW *J Advanced Materials Research* 2014; 1014(10): 323-328.  
<http://dx.doi.org/10.4028/www.scientific.net/AMR.1014.323>
- [9] Horowitz JG, Siegel SD, Primiano FP, *et al.* Computation of respiratory impedance from forced sinusoidal oscillations during breathing *J Computers and Biomedical Research* 1983; 16(6): 499-521.  
[http://dx.doi.org/10.1016/0010-4809\(83\)90037-X](http://dx.doi.org/10.1016/0010-4809(83)90037-X)
- [10] Uchida A, Ito S, Suki B, *et al.* Influence of cheek support on respiratory impedance measured by forced oscillation technique. *J Springerplus* 2013; 2(1): 342-342.  
<http://dx.doi.org/10.1186/2193-1801-2-342>
- [11] Wang H, Chen RC. Application of the forced oscillation technique for assessment of respiratory mechanical properties during noninvasive ventilation. *J Chinese Journal of Biomedical Engineering* 2008; 14(5): 358-363.
- [12] Goldman MD. Clinical Application of Forced Oscillation *J Pulmonary Pharmacology and Therapeutics* 2001; 14(5): 341-350.  
<http://dx.doi.org/10.1006/pupt.2001.0310>