

Simulation of Wearable Microstrip Patch Antenna by Using Textile Material for Ambient RF Energy Harvesting

Khadija El Batal¹, Nabil Chakhchaoui², Adil Eddiai³, M'hammed Mazroui⁴

¹ *Laboratory of Physics of Condensed Matter (LPMC), Faculty of Sciences Ben M'sik Hassan II University, Morocco. khadija.smp.2016@gmail.com*

² *Laboratoire Nanotechnologies Nanosystèmes (LN2) - CNRS IRL-3463 Institut Interdisciplinaire d'Innovation Technologique (3IT), Université de Sherbrooke, 3000 Boulevard Université, Sherbrooke, J1K OA5 Québec, Canada. chakhchaoui.nabil@gmail.com*

³ *Laboratory of Physics of Condensed Matter (LPMC), Faculty of Sciences Ben M'sik Hassan II University, Morocco. adil.eddai@gmail.com*

⁴ *Laboratory of Physics of Condensed Matter (LPMC), Faculty of Sciences Ben M'sik Hassan II University, Morocco. mazroui.m@gmail.com*

Abstract: Future enhancements in radio frequency (RF) energy harvesting technology will make easy the creation of a network with no need of dedicated transmitters, as a reliable source of wireless energy power. Recently, the development and employment of wearable antennas has increased rapidly for application in the miniaturization of wireless communication devices. The principal feature of wearable antennas is that they are designed as garment elements able to transmit or receive wireless signals. In this context, we propose a design of a wearable textile microstrip patch antenna operating for wireless body area network (WBAN) at the resonance frequency $f_r=2.40\text{GHz}$. The microstrip patch antenna with an edge feeding technique is designed and simulated by using the Keysight Advanced Design System (ADS) software. Textile materials have a low dielectric constant that reduces the surface wave losses and increases the impedance bandwidth of the antenna. The chosen dielectric substrate in this work is the jeans fabric with relative permittivity of 1.70, thickness of 1.00 mm and dissipation factor of 0.025. The antenna performance parameters are obtained from ADS Momentum. Simulation results show that antenna has the gain of 3.22 dBi and directivity of 8.10 dBi, showing that the wearable textile microstrip antenna has a good performance.

Keywords: Wearable Antenna, Textile materials, Efficiency, Energy Harvesting

1. INTRODUCTION

Over the past several years, the demand for autonomous and wireless systems has led to a large investigation. The rapid advances in communication and electronic devices have permitted the development of intelligent devices that can be placed in and on the human body. Since the use of conventional batteries is not always cost-effective and their replacement necessitates human effort. Moreover, wearable electronics are powered by a battery system, which need frequent charging. However, power provided sometimes is not easily available to charge these electronic devices. Thus, it becomes as a serious problem for users. This problem can be overcome by requesting to energy harvesting techniques. Energy harvesting is the process of converting the energy extracted from the ambient environment into usable electrical energy. The main function of the harvesting circuit is capturing energy with minimum loss and storing the energy to future use [1]. The ambient energies available comprise mechanical energy [2-4], thermal energy [5-6], solar energy [7-8], and electromagnetic energy [9-10]. Unlike the majority of energy sources, electromagnetic energy sources are permanently available, and omnipresent in our daily lives. Recently, a substantial completion of research has been focused on radiofrequency harvesting energy [11].

Future developments in radio frequency (RF) energy harvesting technology will facilitate the establishment of a network without the necessity of dedicated transmitters, such as a dependable source of wireless energy [12]. This can be achieved by permitting the capture of electromagnetic energy from many different available surrounding RF energy sources, such as Wi-Fi signals [13], mobile base stations and mobile phones [14], FM/AM radio [15], digital

television (DTV) [16]. In addition, many scientists have been growing interests in the study of wireless body area network (WBAN), WBAN connect several electronic devices on human body. There are several frequency bands designated for the WBAN such as the communication system for medical implants (MICS: 400 MHz), the Industrial Scientific Medical band (ISM: 2.40 GHz and 5.80 GHz) [17], also the ultra-wideband (UWB: 3.00-10.00 GHz). Besides, wireless communication systems are consisting of various electronic components, which throughout the years have been miniaturized and fabricated more flexible, in these systems, the antennas conventionally built on rigid substrates [18,19], the utilization of rigid antennas in body-worn positions is difficult because the majority of people do not like to carry uncomfortable antennas. Currently, there is an increasing interest in intelligent clothing with integrated wireless electronics in the garment because of the great potential as a solution for many applications. Whereas, fabricating antennas in textile materials [20] enable developing the interaction between the user and some electronic devices [21] [22]. Furthermore, textile antennas are emerging in a variety of applications including medical [23], military [24], mobile computing [25], sports and wireless monitoring. Moreover, textile materials being globally used and readily available, are optimal materials to design wearable antenna [26], many scientists developed a textile substrate such as polyester, cotton, nylon, etc. to design a flexible antenna that could be easily worn on all parts of the body [27]. On the other hand, the microstrip patch antenna is one of the most commonly used antennas in wearable applications. It has attracted a lot of interest thanks to its advantages such as simple structure, easy manufacturing and its quick integration in microwave circuits. The most popular feeding techniques used for the design of microstrip patch antennas are the transmission line, coaxial probe feed, aperture coupling and proximity coupling [28]. Among these methods, microstrip line feed is one of the easiest methods to construct antennas, which is a simple conductive strip connecting to the patch, and it gives good physical results [29].

Recently, an important number of works have been accomplished in this domain. Baishali Gautam et al. [30] developed two wearable microstrip antennas using Collar stay of formal shirts to achieve 2.1 and 5.2 GHz center frequencies for ISM and Wi-Fi applications. Other investigations, such as the study performed by A. Kavitha and J. N. Swaminathan [31] proposed the Design of a flexible wideband monopole antenna using FR4, teflon and jeans cotton substrates and compared the properties of each material, in order to achieve the performance requirements of modern flexible and wearable electronics and to provide an easy integration with RF circuits. In the same context, Arshad Hassan et al. [32] suggested a printed antenna operating over 1.8 GHz band, made of silver nanoparticle-based radiating element and polyethylene terephthalate (PET) substrate, the proposed antenna was employed for transparent and flexible wearable electronic devices.

In this paper, a wearable microstrip patch antenna is being designed and simulated using ADS software, jeans fabric is used as substrate having low permittivity, which's reduces the surface wave losses and improves the impedance bandwidth of the antenna. The operation frequency of the proposed antenna is set at 2.4 GHz. ISM radio bands are reserved for radio frequency (RF) energy utilized for industrial, scientific and medical applications other than telecommunications. The primary objective of this paper is to study the performance characteristics of a wearable microstrip patch antenna

The remainder of the paper is organized as follows: Section II presents the propriety of materials used in this work, and describes the successive design steps for the design of microstrip antenna. Section III discusses simulation results of different antenna parameters. Finally, Section IV summarizes the main conclusions and perspectives.

2. DESIGN OF MICROSTRIP PATCH ANTENNA

A. Materials and method

In order to design a wearable microstrip patch antenna using textile material, the simulator Advanced Design System (ADS)-Momentum from Agilent Technologies was used. The design of a wearable antenna is based on the microstrip. A typical microstrip antenna made-up of three layers, the conductor patch, substrate and ground plane.

Substrate plays a vital role in antenna design, the purpose of the substrate material of the microstrip antenna is to provide mechanical support for the radiating patch elements and to achieve the desired precision spacing between the ground plane and the patch. In this specific study, jeans fabric is deployed as the substrate material; it is lightweight, cheap and flexible. Substrate thickness h has low dielectric constant $\epsilon_r = 1.70$ that reduces the surface wave losses which are connected to guided wave propagation in the substrates. Therefore, increases the impedance bandwidth of the antenna, thus, permitting the development of antennas with satisfactory efficiency and high gain.

On the other hand, the higher conductive layer (the patch) is the radiation source where electromagnetic energy is released from the edges of the patch and penetrates into the substrate. However, the lower conductive layer (the ground plane) works as a perfect reflective ground plane sending the energy through the substrate and into free space. Both layers are basically consisting of an adhesive copper sheet, which is a good material to conduct electrical energy. Table I shows the features of materials used in this work.

In the contacting method, the RF power is fed directly to the radiating patch using a microstrip line as a connecting element, it is the simplest model and can give good results. For better results feeding line should be having the impedance equal to the characteristics impedance of patch. In this work, the patch antenna was fed with a microstrip line connected to a point inside patch where the input impedance is 50 Ω. Figure 1 shows a typical structure of a wearable microstrip patch antenna, while the selected frequency is the ISM band 2.40 GHz.

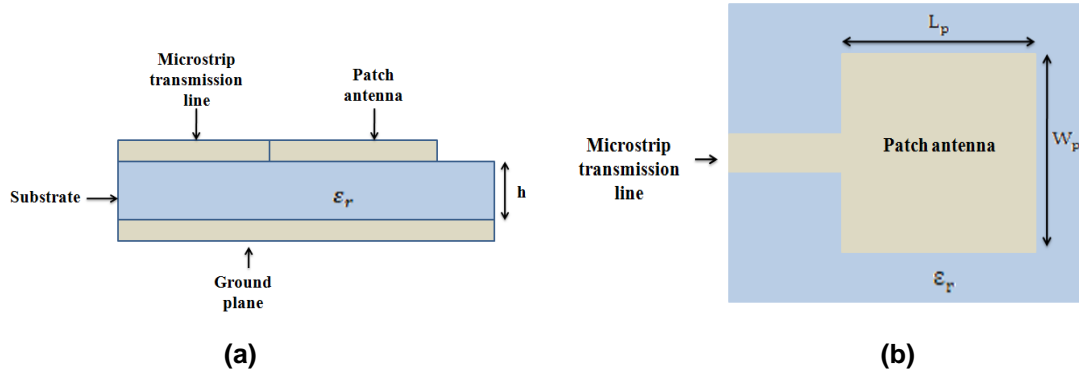

Figure 1: Geometry of the textile antenna. (a) Side view, (b) Front view.

Table I: Features of materials used

| Material type | Thickness(mm) | Permittivity ϵ_r | Conductivity(S/M) | Dissipation factor (Tan δ) |
|---------------|---------------|---------------------------|-------------------|------------------------------------|
| Jeans Fabric | 1.00 | 1.70 | - | 0.0025 |
| Copper | 0.035 | - | 5.8×10^7 | - |

B. Patch Antenna Design

The design methodology has been chosen to minimize the return loss around the resonant frequency, The Proposed parameters calculation formulas are taken from [33], and then optimized with the ADS software .The patch size depends on the substrate dielectric constant ϵ_r and resonant frequency f_r

The width of the patch W is calculated using:

$$W_p = \frac{c}{2f_r \sqrt{\frac{\epsilon_r + 1}{2}}} \tag{1}$$

Where c is the speed of light. The actual length of the patch is written as:

$$L_p = \frac{c}{2f_r \sqrt{\epsilon_{reff}}} - 2\Delta L \tag{2}$$

Based on Eq.(2), the effective dielectric constant ϵ_{reff} is defined as:

$$\epsilon_{reff} = \left(\frac{\epsilon_r + 1}{2}\right) + \left(\frac{\epsilon_r - 1}{2}\right) \times \left(1 + \left(\frac{12h}{W}\right)\right)^{-\frac{1}{2}} \tag{3}$$

Where h is the height of the patch in mm. Also, the length extension ΔL is computed as:

$$\Delta L = 0.421h \left[\frac{(\epsilon_{reff} + 0.3)}{(\epsilon_{reff} - 0.258)} \right] \left[\frac{\left(\frac{W}{h} + 0.246\right)}{\left(\frac{W}{h} + 0.8\right)} \right] \tag{4}$$

The dimensions of the patch antenna and ground plane are calculated using MATLAB software. While ADS LinCalc tool is used to calculate the width and length of the microstrip line. The dimensions of the rectangular microstrip patch

antenna were chosen to maximize the gain pattern and resonate at the desired 2.4GHz frequency. Figure 2 depicts the equivalent circuit of the proposed antenna with the optimal parameters, which include;

- The component Mlin: designates a feed line.
- The component Mloc: refers the dimensions of the patch antenna.

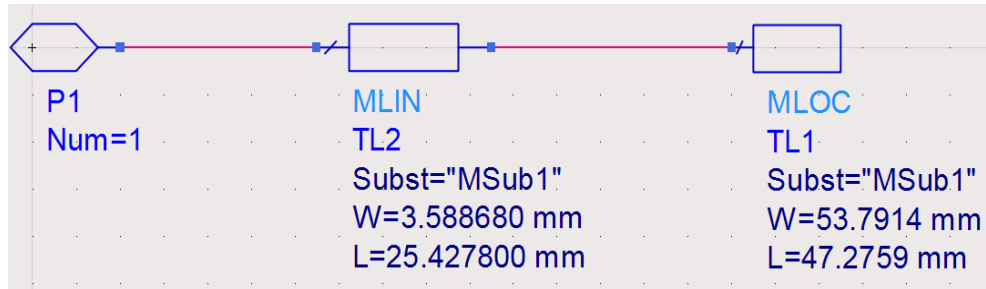

Figure 2: Equivalent circuit of Microstrip Patch Antenna

The physical design of the model of the wearable antenna is created using the layout window, it can be designed in the schematic window and then converted into the layout, as in this case, or be created directly in the layout window. Figure 3 displays the layout of the patch antenna using the fed edge technique.

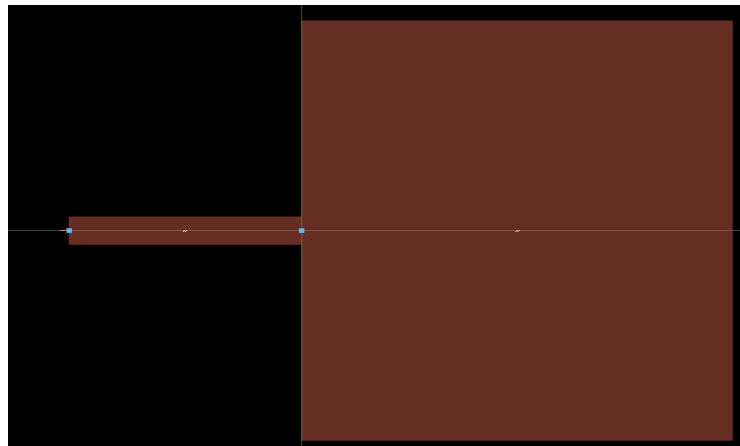

Figure 3: Edge feeding technique Layout.

3. RESULTS AND DISCUSSION

In this section, the wearable microstrip patch antenna performance has been analyzed on the software platform. Simulations are performed for a frequency range from 2.0 to 3.0 GHz in order to determine the antenna parameters.

A. S parameters and VSWR (Voltage Standing Wave Ratio) of the desired antenna.

The return loss is key feature of an antenna. S11 in an antenna is a parameter that states the total of power that is lost to the load and doesn't return as a reflection. Figure 4 illustrates the S11 parameter simulation in terms of magnitude in dB and phase in degree of the designed wearable textile microstrip patch antenna. The antenna should ideally achieve the return loss, S11 lower than -10 dB to be considered as a good performance. It is clearly shown that the proposed antenna located on the free space has the S11 parameter of -14.310 dB at the resonance frequency $f_r=2.40$ GHz. The bandwidth of an antenna is related to the frequency band over which the antenna can operate properly, the designed antenna has a bandwidth of 80 MHz.

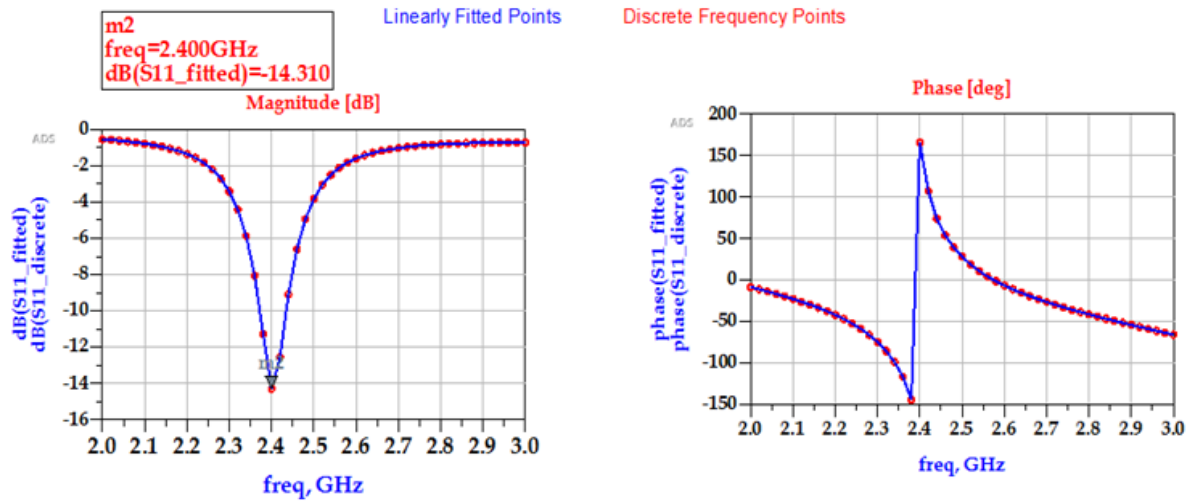

Figure 4: Return loss simulation.

Another essential parameter VSWR, it is determined from the voltage measured along a transmission line leading to an antenna, it is the ratio of the peak amplitude of a standing wave to the minimum amplitude of a standing wave. Moreover, if the VSWR has a lower value, it indicates that the antenna is ideally adapted to the transmission line, and a high power is provided to the antenna. Figure 5 shows the simulated result of VSWR against frequency (GHz). Based on the simulated result, it is noted that, the value of VSWR is almost 1.428 at frequency 2.40 GHz. Thus, the proposed antenna presents the best characteristic of VSWR in the frequency range.

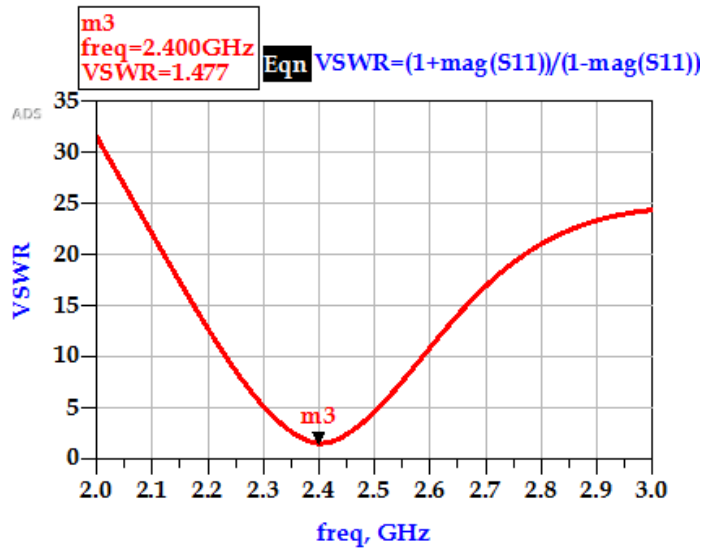

Figure 5: Plot of antenna VSWR versus Frequency.

B. The impedance matching and Radiation Pattern of the desired antenna

The Smith chart was applied under ADS to depict the impedance matching, as shown in Figure 6. The goal is to get the input impedance, Z_{in} of the antenna practically near to the characteristic impedance, Z_0 of 50.000 Ω . If Z_{in} does not match with Z_0 , the signal will be reflected back to the amplifier. Therefore, will not be radiated by the antenna. In this study, the normalized impedance simulation is $Z_0 * (0.945 + j0.726) \Omega$ which is equal to 59 Ω .

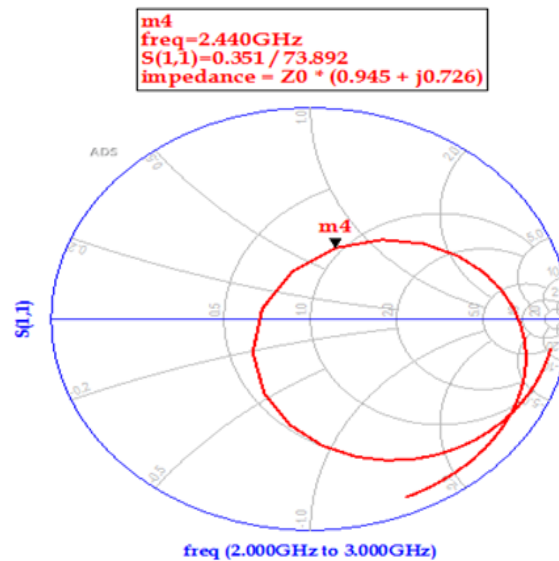

Figure 6: Impedance Matching Simulation

Tool ADS Momentum is a part of the ADS software that is used for designing antenna arrays. This technique is utilized to solve the Maxwell's electromagnetic equation for planer structure in a multilayered dielectric. One of the important characteristic of this tool in antenna simulation analysis is to displayed 2D and 3D graphics for radiation parameter.

Considering the other parameters like the radiation pattern of antenna which is known as a graphical representation characterizes the relative strength of the radiated field in different directions from the antenna, at a constant distance. As illustrated in Figure 7, simulated 3D omnidirectional patterns is created by the designed patch antenna, The proposed antenna is designed to radiate Perpendicular to its patch surface, it is clearly shows that the designed antenna array generates an isotropic radiation pattern.

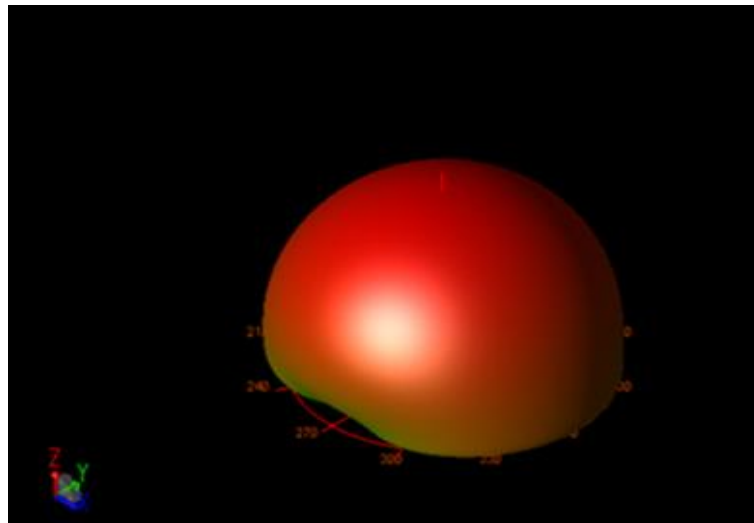

Figure 7: 3D radiation pattern.

C. Gain, directivity and radiated power of the desired antenna

Directivity, Gain and power radiated are essential parameters for evaluating the efficiency of the antenna.

The gain of the antenna is defined as “The ratio of the intensity, in a given direction, to the radiation intensity that would be obtained if the power accepted by the antenna were radiated isotopically.” [33]. According to the figure 8(a), the gain has started decreasing from half wavelength and upon completing one wavelength due to the extensive line and material losses along with the reduction in bandwidth. Furthermore, the frequency at which the reflection

coefficient is minimal corresponds to that at which the gain is maximum. The maximum gain of 3.22015 dBi is achieved at $f_r = 2.40$ GHz.

Directivity is a measure that describes the ability of an antenna to concentrate the energy, it radiates in a particular direction of space, it is controlled only by the pattern. In this case, the designed microstrip antenna has the simulated directivity of 8.10426 dBi as indicated in figure 8 b. It is theoretically in the normal range. Moreover, the designed antenna has a radiated power of 7.8185×10^{-4} Watts shown in figure 8 c for input power of 2.40732 mW at $f_r = 2.40$ GHz. The electrical parameters of the proposed antenna have been shown in Table 2. In sum, the results achieved from the proposed Microstrip patch antenna show that the wearable microstrip antenna has a good performances. Hence, it improves the suitability of the utilization of wearable antennas in medical applications.

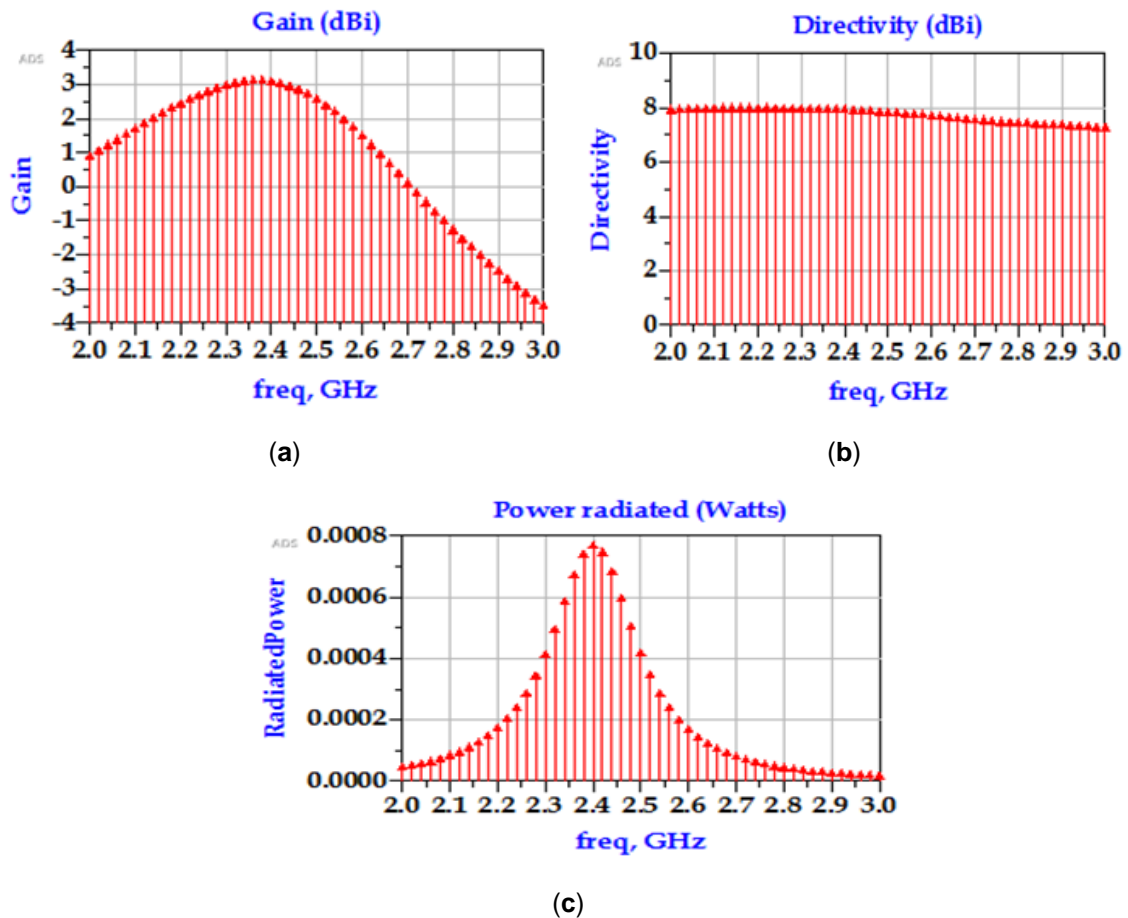

Figure 8: (a) Gain, (b) Directivity and (c) Radiated Power Simulation versus frequency

4. CONCLUSION

RF energy harvesting technology has a significant future in low power consumer electronics and wireless sensor networks. Actually, the utilization of textile antennas for RF energy harvesting can be a solution to power wearable electronics devices and provides better aesthetics. Moreover, it makes the embedding of electronic devices less obtrusive. The microstrip antenna is a perfect candidate for wearable applications, its light weight, small dimensions and simplicity of manufacturing. In this document, the wearable microstrip patch antenna on jeans fabric has been effectively designed and simulated using advanced design system. The suggested system minimizes the return loss of the microstrip patch antenna, as -14.310 dB and it operates on the desired frequency range. Projected antenna were optimized to obtain the bandwidth (≈ 80 MHz for $VSWR < 2$) with a stable radiation pattern. Furthermore, the antenna shows great in terms of gain, directivity and radiated power. This study proves that the wearable antenna that is a part of the fabric design shows excellent performances and does not need a high power supply. It may be concluded that the proposed antenna can be very beneficial in various wireless implementations, including higher frequency also, the good characteristics of the antenna confirm its suitability for wearable devices. Nevertheless, the interaction between the wearable antenna and the human body can never be averted and hence necessitates further

research. Moreover, future work will focus on the employment of electro-textiles rather than conductive copper materials so as to improve the incorporation of the antenna into clothing.

5. REFERENCES

- [1]. M. Piñuela, P. D. Mitcheson, S. Lucyszyn, "Ambient RF energy harvesting in urban and semi-urban environments". IEEE. T. Microw. Theory, vol 61(7), pp. 2715-2726, (2013).
- [2]. A. Eddiai, M. Meddad, R. Farhan, M. Mazroui, M. Rguiti and D. Guyomar, "Using PVDF piezoelectric polymers to maximize power harvested by mechanical structure" Superlattice Microst, vol. 127, pp. 20-26, 2019.
- [3]. A. Eddiai, M. Meddad, S. Touhtouh, A. Hajjaji, Y. Boughaleb, D. Guyomar, S. Belkhiat, B. Sahraoui, "Mechanical characterization of an electrostrictive polymer for actuation and energy harvesting", J. Appl. Phys, Vol.111, pp. 124115, (2012).
- [4]. M. Meddad, A. Eddiai, D. Guyomar, S. Belkhiat, A. Cherif, K. Yuse and A. Hajjaji, "An adaptive prototype design to maximize power harvesting using electrostrictive polymers". J. Appl. Phys, vol. 112, no 5. 054109, 2012.
- [5]. D. C. Hoang, Y. K. Tan, H. B. Chng, S. K. Panda, "Thermal energy harvesting from human warmth for wireless body area network in medical healthcare system". In 2009 International Conference on Power Electronics and Drive Systems (PEDS), pp. 1277-1282, IEEE (2009, November).
- [6]. T. J. Abraham, D. R. MacFarlane and J. M. Pringle, "High Seebeck coefficient redox ionic liquid electrolytes for thermal energy harvesting,". Energ. Environ. Sci, vol. 6, no 9, p. 2639-2645, 2013.
- [7]. R. Khenfer, S. Benahdoug, M. Meddad, M. Mostefai, A. Eddiai, and K. Benkhouja, "Effect of temperature on the PV cells and improving their performance by the use of thermo generators". Molecular Crystals and Liquid Crystals, Vol. 627, no 1, pp. 23-28, 2016.
- [8]. O. López-Lapeña, M. T. Penella and M. Gasulla, "A new MPPT method for low-power solar energy harvesting". IEEE. T. Ind. Electron, vol. 57, no 9, pp. 3129-3138, 2009.
- [9]. M. Piñuela, P. D. Mitcheson and S. Lucyszyn, "RF energy harvesting in urban and semi-urban environments", IEEE.T. Microw.Theory, vol. 61, no 7, p. 2715-2726, 2013.
- [10]. H. Jabbar, Y. S. Song and T. T. Jeong, "RF energy harvesting system and circuits for charging of mobile devices", IEEE. T. Consum. Electr, vol. 56, no 1, p. 247-253, 2010.
- [11]. V. Kuhn, C. Lahuec, F. Seguin and C. Person, "A multi-band stacked RF energy harvester with RF-to-DC efficiency up to 84%", IEEE.T. Microw.Theory, vol. 63, no 5, pp 1768-1778, 2015.
- [12]. A. Okba, A. Takacs, H. Aubert, S. Charlot and P. F. Calmon, "Multiband rectenna for microwave applications", CR Phys, vol. 18, no 2, pp. 107-117, 2017.
- [13]. V. Talla, S. Pellerano, H. Xu, A. Ravi and Y. Palaskas, "Wi-Fi RF energy harvesting for battery-free wearable radio platforms", In 2015 IEEE International Conference on RFID (RFID), pp. 47-54, (2015, April).
- [14]. N. Md Din, C. K. Chakrabarty, A. Bin Ismail, K. K. A. Devi and W. Y. Chen, "Design of RF energy harvesting system for energizing low power devices", Prog. Electromagn. Res, vol. 132, pp. 49-69, 2012.
- [15]. K. Xie, Y. M. Liu, H. L. Zhang and L. Z. Fu, "Harvest the ambient AM broadcast radio energy for wireless sensors", J. Electromagnet. Wave, vol. 25, no 14-15, pp, 2054-2065, 2011.
- [16]. C. Mikeka, H. Arai, A. Georgiadis and A. Collado, "DTV band micropower RF energy-harvesting circuit architecture and performance analysis", In 2011 IEEE International Conference on RFID-Technologies and Applications, pp. 561-567, (2011, September).
- [17]. R. Sánchez-Montero, C. Camacho-Gómez, P. L. López-Espí and S. Salcedo-Sanz, "Optimal design of a planar textile antenna for industrial scientific medical (ISM) 2.4 GHz wireless body area networks (WBAN) with the CRO-SL algorithm", Sensors, vol. 18, no 7, p, 1982, 2018.
- [18]. L. Fadel, L. Oyhenart, R. Bergès, V. Vigneras and T. Taris, "A concurrent 915/2440 MHz RF energy harvester", Int. J. Microw. Wirel T, vol. 8, no 3, pp. 405-413, 2016.
- [19]. M. Nalini, J. N. Kumar, R. M. Kumar and M. Vignesh, "Energy harvesting and management from ambient RF radiation", In 2017 International Conference on Innovations in Green Energy and Healthcare Technologies (IGEHT), pp. 1-3, (2017, March).
- [20]. U. Ali, S. Ullah, M. Shafi, S. A. Shah, I. A. Shah and J. A. Flint, "Design and comparative analysis of conventional and metamaterial-based textile antennas for wearable applications", Int. J. Numer. Model. EI, vol. 32, no 6, p.2567, 2019.
- [21]. A. Tsois, W. G. Whittow, A. A. Alexandridis, J. C. Vardaxoglou, "Embroidery and related manufacturing techniques for wearable antennas: challenges and opportunities", Electronics, vol. 3, no 2, pp. 314-338, 2014.
- [22]. R. Salvado, C. Loss, R. Gonçalves and P. Pinho, "Textile materials for the design of wearable antennas: A survey", Sensors, vol. 12, no 11, pp. 15841-15857, 2012.
- [23]. A. B. Mustafa and T. Rajendran, "An effective design of wearable antenna with double flexible substrates and defected ground structure for healthcare monitoring system", J. Med Syst, vol. 43, no 7, p.186, 2019.
- [24]. T. Kaija, J. Lilja and P. Salonen, "Exposing textile antennas for harsh environment", In 2010-Milcom 2010 Military Communications Conference, pp. 737-742, 2010.
- [25]. C. Loss, R. Gonçalves, C. Lopes, R. Salvado and P. Pinho, "Textile antenna for RF energy harvesting fully embedded in clothing", In 2016 10th European Conference on Antennas and Propagation (EuCAP), pp. 1-4, IEEE, (2016, April).
- [26]. C. Hertleer, A. Tronquo, H. Rogier and L. Van Langenhove, "The use of textile materials to design wearable microstrip patch antennas", Text. Res. J, vol. 78, no 8, pp. 651-658, 2008.
- [27]. S. J. Ha, Y. B. Jung, D. H. Kim and C. W. Jung, "Textile patch antennas using double layer fabrics for wrist-wearable applications", Microw. Opt. Techn. Let, vol. 54, no 12, pp. 2697-2702, 2012.
- [28]. C. A. Balanis, (Ed.), "Modern antenna handbook", John Wiley & Sons, 2011.
- [29]. I. Singh and V. S. Tripathi, "Micro strip patch antenna and its applications: a survey", Int. J. Comp. Tech. Appl, vol. 2, no 5,

- pp. 1595-1599, 2011.
- [30]. B. Gautam, P. Verma, A. Singha, H. Islam, O. Prakash and S.Das, "Design of multiple collar stay antennas for wireless wearable compact devices", *Microw. Opt. Techn. Let.*, vol. 62, no 2, pp.743-749, 2020.
- [31]. A. Kavitha, J. N. Swaminathan, "Design of flexible textile antenna using FR4, jeans cotton and teflon substrates", *Microsyst. Technol.*, vol. 25, no 4, pp. 1311-1320.
- [32]. A. Hassan, S. Ali, J. Bae, C. H. Lee, "All printed antenna based on silver nanoparticles for 1.8 GHz applications", *Appl. Phys.A*, vol. 122, no 8, p. 768, 2016.
- [33]. C.A.Balanis, "Antenna Theory, Analysis and Design," Johnwiely&sons, New York, 1997.

DOI: <https://doi.org/10.15379/ijmst.v10i4.2243>

This is an open access article licensed under the terms of the Creative Commons Attribution Non-Commercial License (<http://creativecommons.org/licenses/by-nc/3.0/>), which permits unrestricted, non-commercial use, distribution and reproduction in any medium, provided the work is properly cited.